



THE UNITED KINGDOM VEHICLE APPROVAL AUTHORITY

COMMUNICATION CONCERNING GB TYPE-APPROVAL <sup>(1)</sup> OF A TYPE OF SPRAY  
SUPPRESSION SYSTEM AS A COMPONENT/SEPARATE TECHNICAL UNIT WITH REGARD TO  
REGULATION (EU) NO 109/2011, AS IT HAS EFFECT IN DOMESTIC LAW, AND AS LAST  
AMENDED BY STATUTORY INSTRUMENT 2022/1273

GB type-approval number: g11\*109/2011\*2022/1273\*00204\*00

Reason(s) for extension: Not applicable

**SECTION I**

- 0.1. Make (trade name of manufacturer): FICHET SA
- 0.2. Type: Standard
- 0.3. Means of identification of type, if marked on the separate technical unit <sup>(2)</sup>: Not applicable
- 0.3.1. Location of that marking: Not applicable
- 0.5. Name and address of manufacturer:
- FICHET SA  
Za Le Mas  
64, Rue Du Ruisseau D'aumas  
07430 Davezieux  
France
- 0.7. Location and method of affixing of the GB approval mark: The marking is carried out by hot stamping on the visible external shape of the part
- 0.8. Name(s) and address(es) of assembly plant(s):
- Manufacture De Caoutchouc Fichet  
423, Rue Jules Romain – Zi De La Lombardière  
07430 Davezieux  
France

0.9. Name and address of the manufacturer's representative (if any):

Boydell and Jacks Ltd  
Wingard House, Lincoln Street, Healey Wood Industrial Estate  
Burnley  
Lancashire  
BB11 2HW  
United Kingdom

## SECTION II

1. Additional information (where applicable): See addendum
2. Technical service responsible for carrying out the tests: UTAC
3. Date of test report: 12 March 2012
4. Number of test report: 12/01945
5. Remarks (if any): None
6. Place: BRISTOL
7. Date: 06 FEBRUARY 2024
8. Signature:



C McCABE  
Chief Technical and Statutory Operations Officer

9. The index to the information package lodged with the approval authority, which may be obtained on request, is attached.

- (1) Delete where not applicable.
- (2) If the means of identification of type contains characters not relevant to describe the vehicle, component or separate technical unit types covered by this information document, such characters shall be represented in the documentation by the symbol '?' (e.g. ABC??123??).

**ADDENDUM**

to GB type-approval certificate No g11\*109/2011\*2022/1273\*00204\*00

1. Additional information
  - 1.1. Operating principle of device: energy-absorption<sup>(1)</sup>
  - 1.2. Characteristics of spray suppression devices (brief description, trademark or name, number(s)): See manufactures documentation
  
5. Remarks (if any): None

(1) Delete where not applicable.



Vehicle  
Certification  
Agency

THE UNITED KINGDOM VEHICLE APPROVAL AUTHORITY

APPROVAL NUMBER: g11\*109/2011\*2022/1273\*00204\*00

**INFORMATION PACKAGE CONTENTS**

**INDEX REVISION NUMBER: 00**

Total number of sheets: 6 (Six)

Reasons for Revision: Not applicable

<b>Company name</b> Fichet SA		<b>Type of document</b> GB Scheme cover page	
<b>Name of document</b> GB Cover page – Netway	<b>Version</b> 02	<b>Date</b> 10 November 2023	<b>Page(s)</b> 1 (1)

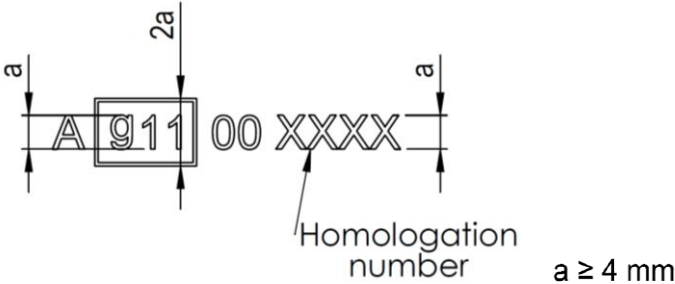
<b>Manufacturer's representative:</b>	Boydell and Jacks Ltd Wingard House, Lincoln Street, Healey Wood Industrial Estate Burnley Lancashire BB11 2HW United Kingdom
<b>GB legislation being applied for:</b>	UK Statutory Instruments 2022 No. 1273
<b>EU information document(s) reference (Type code or document reference):</b>	UE 109-2011
<b>Fields within the EU information document which is not applicable for GB:</b>	
<b>Differences between EU content and GB content:</b>	
<b>Other information:</b>	<p>According 2022 N° 1273, new marking will be added on parts</p>  <p>SMMT Organisation code : 40700</p>



**FICHET**

---

DISPOSITIF ANTI-PROJECTIONS  
*SPRAY-SUPPRESSION SYSTEM*

**NETWAY**

**DOSSIER ReD 02 001**

REGLEMENT UE N° 109/2011



## 0. GENERAL

### 0.1 FICHET SA

#### 0.2.1 Commercial name : NETWAY

#### 0.5 Name and address of the manufacturer

FICHET SA  
ZA Le MAS  
64, rue du ruisseau d'Aumas  
07430 DAVEZIEUX  
FRANCE  
Tél : 04.75.32.42.42  
Fax : 04.75.67.57.16

#### 0.7 Marking of homologation number

The marking is carried out by hot stamping on the visible external shape of the part.

#### 0.8 Address of the assembly plant

Manufacture de Caoutchouc Fichet  
423, Rue Jules Romain – ZI de la Lombardière  
07430 DAVEZIEUX  
FRANCE  
Tél : 04.75.33.65.66  
Fax : 04.75.33.49.07

## 1. DESCRIPTION OF THE DEVICE

### 1.1 Technical description

Water energy absorption system.

The device includes a bottom plate on which a previously shaped grid is assembled (presence of waves). A second grid is then assembled on the first. Thus, The assembly creates an intermediate space where water can circulate.

Views of the system

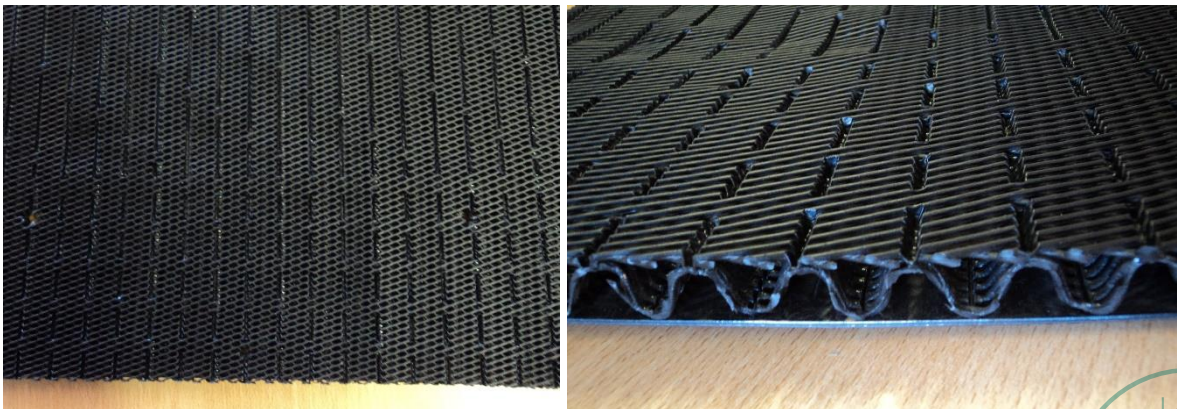



## 1.2 Material used

The system is made of plastic - (PE) or Polypropylène (PP).

## 1.3 Drawings

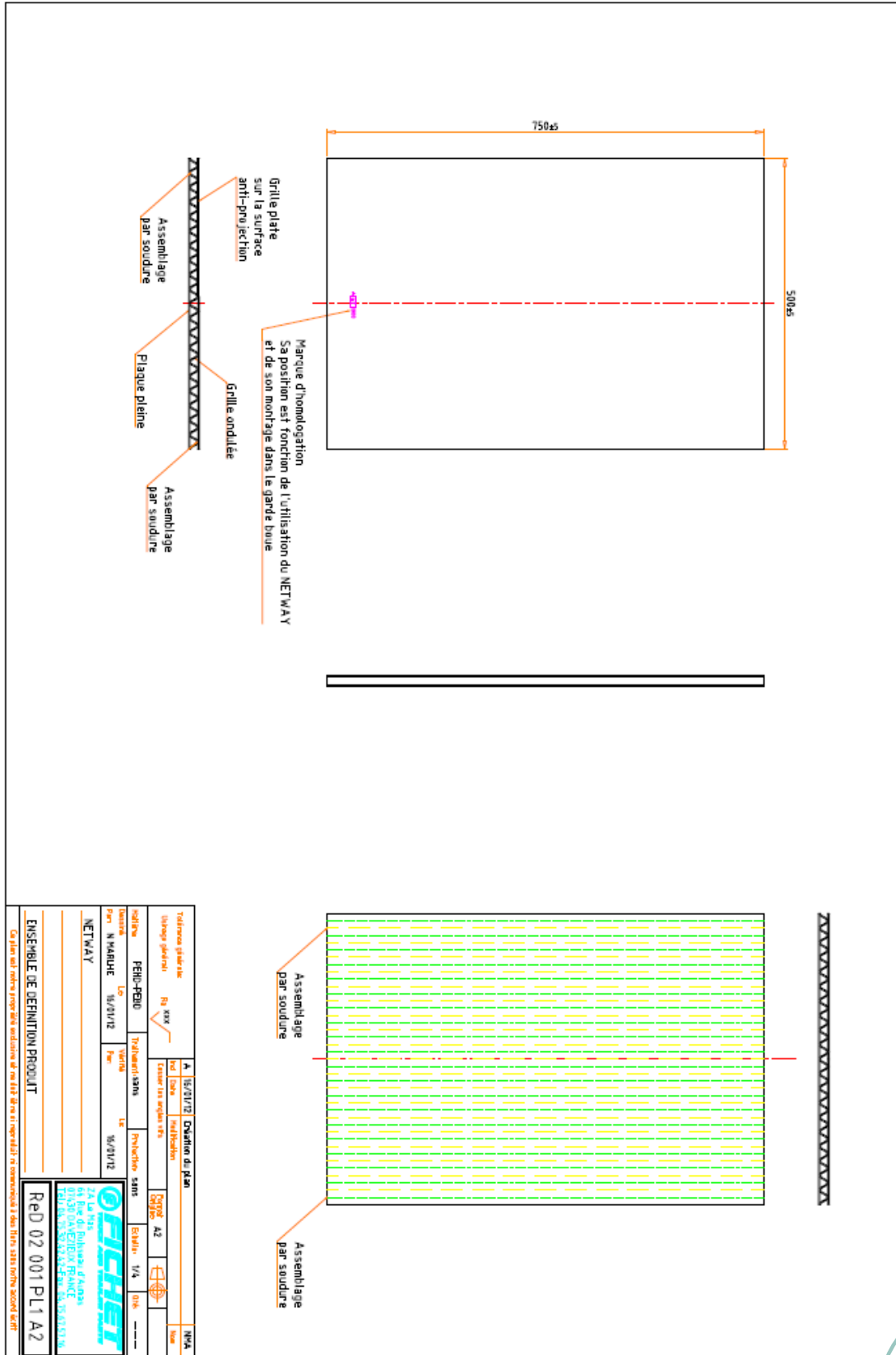



**FICHET**

---





Grille plate  
sur la surface  
anti-projection

Grille ondulée  
Waved grill

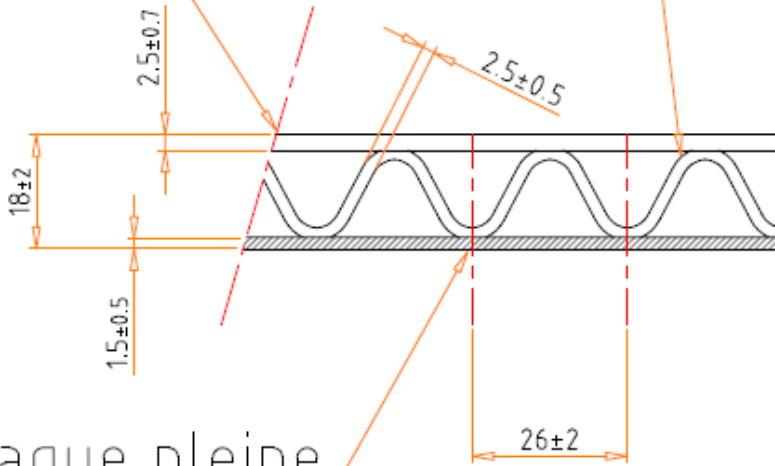

Plaque pleine  
Full plate

Tolérance générale:		A	16/01/12	Création du plan		NMA
Utilage général:		Ex	XXX	Conserver les angles vifs	Format	A2
Matériau:		PEHD-PEBD	Traitement:	sans	Protection:	sans
Dessiné:		Lot	16/01/12	Verifié:	Lot	16/01/12
Parti:		N MARLHE	Parti:	16/01/12		
NETWAY		ZA Le Mas 64 Rue du Puisseau d'Aumas 07430 DAVEZIEUX FRANCE Tél: 04 75 37 43 43 Fax: 04 75 67 57 16				
DETAIL DES ONDULATIONS		<b>ReD 02 001 PL2 A2</b>				

Caplan est entre propriété exclusive et se doit être ni reproduit ni communiqué à des tiers sans votre accord écrit



06-Feb-24